

AUDIO MANAGEMENT SYSTEM

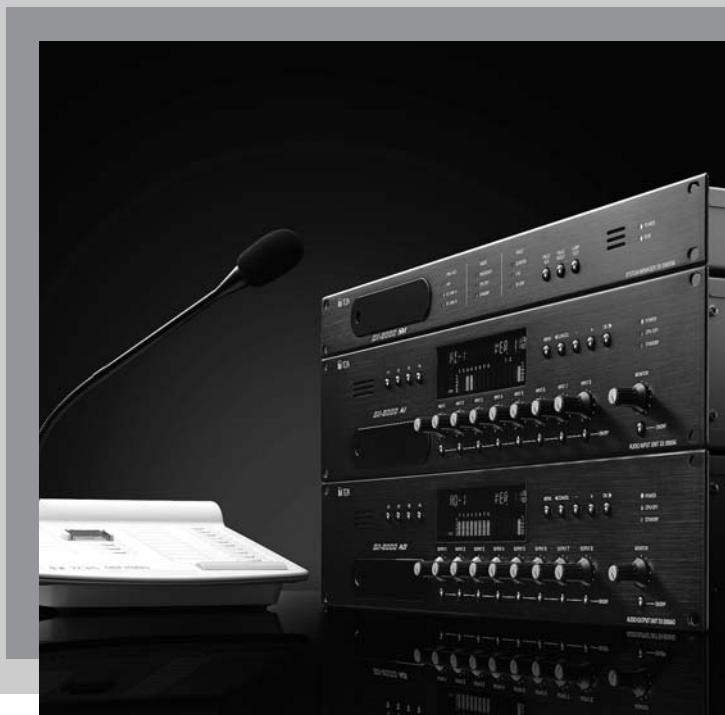

SX-2000

DESCRIPTION

The SX-2000 Series Audio Management System is network-based in order to allow convenient distribution of components in various locations, with only commercial switching hubs required. Public address performance is superb at a 48kHz sampling rate and all AD/DA conversion is 24-bit PCM. Audio Input and Output Units meet user requirements with a maximum of 64 inputs and 256 outputs, and a System Manager allows up to 16 channels to be simultaneously broadcast. Full control over 1416 inputs/outputs is provided with the assistance of 32-channel Input and Output Control units. The system is versatile, with multiple program sources from CD players to digital PA devices and remote microphones. The SX-2000 is compatible with the EN 54* Standard for voice evacuation system. A Fireman's Microphone ensures reliable emergency broadcasts. In addition, the power supply is over-engineered, with each device in the system having dual power inputs for interrupted performance should one power source fail. All system components are able to operate on DC power alone.

* EN 54 is a standard of the European Union (EU) for fire alarm systems, ensuring high product quality and reliability, and enabling better integration of Voice Alarm (VA) and Public Address (PA). EN 54 plays a significant role in the market for voice evacuation equipment, as the member states of the European Union replace their local standards with the EN 54 standard. All emergency voice evacuation systems marketed in the member states of the European Union are required to be certified to this standard.

The SX-2000 system is certified on the European Standard EN 54-16 with CPD number 1134-CPD-102.

The VX-2000DS (ER/UK version) Power manager and VX-200PS (ER/UK version) power supply are certified on the European Standard EN 54-4 with CPD number 1134-CPD-083.

FEATURES

- Versatile installation possibilities suit a wide range of applications
- Convenient system component distribution to different locations through a network
- Full digital signal processing for improved performance
- Input and Output Control Units
- Input and Output Audio Units
- EN 54 Standard compatibility
- Dedicated Fireman's Microphone
- Multipurpose remote control
- Fully operable on DC power
- Power failure measurement
- Redundant dual power supply
- Fully redundant dual network
- Additional analog backup
- Outstanding user friendliness
- Security-conscious design
- Quick maintenance
- Future expandability
- Compact and space saving
- Reduced power consumption
- Terminal Unit for trunk to feeder cable connection
- Software setting capability



SX-2000SM

System Manager

EN 54
16



SX-2000SM System Manager is designed for use in TOA's Matrix System and can be mounted in an EIA Standard component rack (1-unit size). It can be used in combination with an optional audio input unit, audio output unit and remote microphone of the SX-2000 Series to make up a complete matrix system and can perform audio signal routing and priority control for the entire system. The SX-2000SM itself is equipped with 8 control inputs, 8 outputs, failure status outputs, failure data inputs/switches, access indicators, mode indicators and failure indicators enabling a wide range of control and status monitoring. Control input line failure can be detected by connecting resistors to its line. The SX-2000SM has a function to supply a stabilized 24V DC. Each control can be performed by way of a CF card inserted into the SX-2000SM unit. Operations of the entire system can be recorded and their contents stored on a CF card as an operation log. The SX-2000SM also features two power inputs enabling the creation of a dual-redundant power system. Equipped with two inputs for connecting to the Emergency Power Supply units, making it possible to configure the system to operate during a power failure.

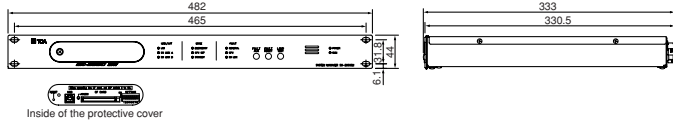

Inside of the protective cover

SPECIFICATIONS

Power Source	Usable power supply unit: VX-200PS 24V DC (operational range: 20V – 40V DC) Two power inputs construction enables dual- redundant power supply.
Current Consumption	1.1A or less (maximum value in the power operating range) 0.8A or less (when operated on 24V DC)
Indication/Operation	SX link access indicator: 2 LAN access indicator: 1 Mode indicator: 3 (EMERGENCY/STANDBY/CPU OFF) Failure indicator: 3 (GENERAL/CPU/SX LINK) Power indicator: 1 (POWER) Run indicator: 1 (RUN) Failure control switch: 3 (AUX/RESET/LAMP TEST)
SX Link Network I/F Matrix System Specification	2 × 100BASE-TX circuits, RJ45 connector Bus: 16 Audio input: Max. 64 ch Audio output: Max. 256 zones Contact input: Max. 1416 Contact output: Max. 1416 Priority control: 512 steps Event log: Up to 10,000 logs per file (up to 32 files available) Failure log: Up to 100 logs per file (up to 32 files available)
Matrix System Configuration	Connectable SX-2000AI/2100AI No.: Max. 8 units Connectable SX-2000AO/2100AO No.: Max. 32 units Connectable SX-2000CI No.: Max. 32 units Connectable SX-2000CO No.: Max. 32 units Connectable RM-200SA No.: Max. 64 units (up to 8 RM-200SF/RM-200SA per SX-2100AI)
Connection Cable/Device	Shielded Category 5 twisted pair cable for LAN (CAT5-STP) (Connect SX-2100AI and SX-2000AO/SX-2100AO via the switching hub specified by TOA)
Switching Hub Maximum Cable Distance	7 stages 100m (between this unit and a switching hub)
LAN Network I/F	1 × 10 BASE-T/100 BASE-TX circuit (selectable by automatic recognition), RJ45 connector for maintenance use
Network Protocol Connection Cable Maximum Cable Distance	TCP/IP Shielded Category 5 twisted pair cable for LAN (CAT5-STP) 100m (between this unit and a switching hub or PC)
Analog Link Input/Output Connector Connection Cable	Output: 2, RJ45 connector Shielded Category 5 twisted pair cable (CAT5-STP) (1 pair of audio wire + 1 pair to "CPU OFF" + 1 pair of control wire (system reset/standby) + 1 pair of connection check wire) Total length of analog audio link: 800m
Maximum Cable Distance	
DS Link Usable Unit Connector/Cable Maximum Cable Distance	VX-2000DS 2 interface, RJ45 Connector, Shielded Category 5 twisted pair cable (CAT5-STP) 5m

Failure Data Input	3 inputs (ACK/RESET/LAMP TEST), no-voltage make contact input, open voltage: 24V DC, short-circuit current: 2mA, photo coupler input, removable terminal block (12 pins)
Failure Data Output	4 outputs (CPU FAULT/GENERAL FAULT/CPU OFF/BUZZER), C contact, no-voltage make contact output, relay contact output (withstand voltage: 40V DC, control current: 2 – 300mA), RJ45 connector
Control Input	8 inputs, no-voltage make contact input, open voltage: 24V DC, short-circuit current: 2mA, photo coupler input, removable terminal block (12 pins)
Surveillance Section for The Control Input Line	Connection resistance to make the function inactive: 20kΩ ±5% Connection resistance to make the function active: 10kΩ ±5% Connector cable: Twisted pair cable (shielded type is recommended) Maximum cable distance: 10m
Control Output	8 outputs, C contact, no-voltage make contact output, relay contact output (withstand voltage: 40V DC, control current: 2 – 300mA), removable terminal block (12 pins)
24V DC Output Output Voltage Maximum Feeding Current	24V DC ±10% or less 100mA
Memory Card	Insertion slot: 1 (use of supplied CF card (128MB)), set data and log data stored
Operating Temperature	0°C to +40°C
Operating Humidity	35% to 80% RH (no condensation)
Finish	Panel: Aluminum, black, alumite, Case: Surface-treated steel plate
Dimensions	482 (W) × 44 (H) × 333 (D)mm
Weight	3.8kg
Accessory	CD (PC setting software) × 1, EV-CF128M (CF card) × 1, Removable terminal plug (4 pins) × 1, Removable terminal plug (12 pins) × 4, Rack mounting screw × 4, Driver × 1

SX-2100AI

Audio Input Unit

EN 54
16



The SX-2100AI is an audio input of the matrix system and can be mounted in an EIA equipment rack (2U size). Multiple units can be decentralized in a whole system. It features modular construction that allows it to handle from two to eight inputs per unit. Audio signals are transmitted digitally to the audio output unit, but an analog audio output function (1 channel) enables simultaneous all-zone calls for use in emergency situations. Audio input levels (post-fader levels) are indicated on the level meters provided for each input channel. Volumes can be adjusted for each channel using either volume controls on the front panel or the SX-2000 software. The volume controls can be locked using the SX-2000 software. Any input channel can be monitored using the internal speaker. It is also equipped with 16 control inputs, and 16 control outputs. It is equipped with two power inputs, allowing for a redundant power system.

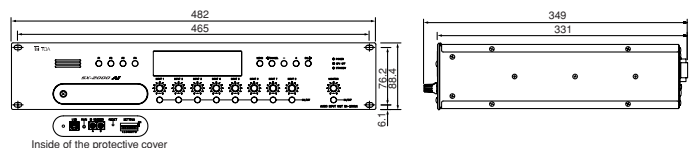
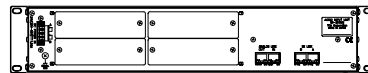

Inside of the protective cover

SPECIFICATIONS (SX-2100AI)

Power Source	Usable power supply unit: VX-200PS 24V DC (operational range: 20V – 40V DC) Two power inputs construction enables dual- redundant power supply.
Current Consumption	2.0A or less (maximum value in the power operating range) 1.5A or less (when operated on 24V DC) Note: But except current consumption of the external equipment of which power is supplied from the unit.
Indication	18 alphanumeric characters, Level indication (8 inputs, monitor), Status indicators, Power indicator, Standby indicator, CPU OFF indicator
Operation	Function button, Input level control, Monitor speaker volume control, ON/OFF switch, Operation button
Audio Input	8 inputs, module construction (max. 4 modules, modules optional) monitoring possible using built-in speaker.
Audio Input Characteristic	Sampling frequency: 48kHz
No. of Connectable Remote Microphones	Max. 8
Power Distribution to Remote Microphones	Up to a total of 8A
SX Link	
Network I/F	2 x 100BASE-TX circuits, RJ45 connector, decentralized installation possible
Connection Cable/Device	Shielded Category 5 twisted pair cable for LAN (CAT5-STP) To be connected via the switching hub specified by TOA Note: This network must be made completely independent from other LAN.
Maximum Cable Distance	100m (between this unit and a switching hub)
Analog Link	
Input/Output Connector	Input: 1 input, RJ45 connector Output: 1 output, RJ45 connector
Connection Cable	Shielded Category 5 twisted pair cable for LAN (CAT5-STP) (1 pair of audio wire + 1 pair of control wire (CPU OFF) + 1 pair of control wire (system reset/standby) + 1 pair of connection check wire)
Maximum Cable Distance	Total length of analog audio link: 800m
Control input	16 inputs, no-voltage make contact input, open voltage: 40V DC or less, short-circuit current: 2mA, photo coupler input, removable terminal block (16 pins)
Control Output	16 outputs, A contact: normally open (changeable to B contact: normally closed), no-voltage make contact output, relay contact output (withstand voltage: 40V DC, control current: 2 – 300mA), removable terminal block (16 pins)
Operating Temperature	0°C to +40°C
Operating Humidity	35% to 80% RH (no condensation)
Finish	Panel: Aluminum, black, alumite, Case: Surface-treated steel plate
Dimensions	482 (W) x 88.4 (H) x 349 (D)mm
Weight	7.2kg
Accessory	Removable terminal plug (4 pins) x 1, Removable terminal plug (16 pins) x 4, Rack mounting screw x 4
Option	Remote microphone interface module: SX-200RM MIC/LINE input module: D-921E, D-921F, D-922E, D-922F Stereo input module: D-936R Note: Modules other than described above cannot be used.

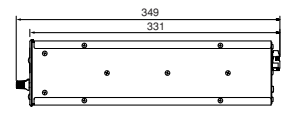
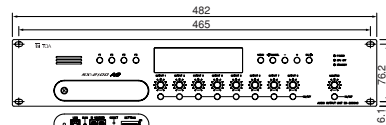
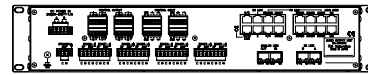

Inside of the protective cover

SPECIFICATIONS (SX-2100AO)

*0dB = 1V

Power Source	Usable power supply unit: VX-200PS 24V DC (operational range: 20V – 40V DC) Two power inputs construction enables dual- redundant power supply.
Current Consumption	1.7A or less (when operated on the voltage where the current flows most) 1.2A or less (when operated on 24V DC) Note: But except current consumption of the external equipment of which power is supplied from the unit.
Indication	18 alphanumeric characters, Level indication (8 outputs, monitor), Status indicators, Power indicator, Standby indicator, CPU OFF indicator
Operation	Function button, Output level control, Monitor speaker volume control, ON/OFF switch, Operation button
PA Link	
Audio Output	8 outputs and standby AMP, 0dB*, suitable load: 600Ω or above, electronically-balanced, RJ45 Connector monitoring possible using built-in speaker
Audio Output Characteristic	Frequency response: 20Hz – 20kHz Sampling frequency: 48kHz D/A converter: 24 bit
Connection Cable	Shielded Category 5 twisted pair cable (CAT5-STP)
Maximum Cable Distance	5m
Usable Amplifier	VP-2064, VP-2122, VP-2241 or VP-2421 (VP-200VX is required for each amplifier)
Local Audio Input	
Audio Input	2 inputs, 0dB*, 10kΩ, electronically-balanced, RJ45 Connector
Audio Input Characteristic	Frequency response: 20Hz – 20kHz Sampling frequency: 48kHz A/D converter: 24 bit
Control Input	2 inputs, no-voltage make contact input, open voltage: 12V DC, short-circuit current: 2mA, photo coupler input
Connection Cable	Shielded Category 5 twisted pair cable (CAT5-STP)
SX Link	
Network I/F	2 x 100 BASE-TX circuits, RJ45 connector, decentralized installation possible
Connection Cable/Device	Shielded Category 5 twisted pair cable for LAN (CAT5-STP) To be connected via the switching hub specified by TOA Note: This network must be made completely independent from other LAN.
Maximum Cable Distance	100m (between this unit and a switching hub)
Analog Link	
Input/Output Connector	Input: 1 input, RJ45 connector Output: 1 output, RJ45 connector
Connection Cable	Shielded Category 5 twisted pair cable for LAN (CAT5-STP) (1 pair of audio wire + 1 pair to "CPU OFF" + 1 pair of control wire (system reset/standby) + 1 pair of connection check wire)
Maximum Cable Distance	Total length of analog audio link: 800m
DS Link	
Usable Unit	VX-2000DS
Connector/Cable	2 interface, RJ45 Connector, Shielded Category 5 twisted pair cable (CAT5-STP)
Maximum Cable Distance	5m
C/CO Link	
Usable Unit	SX-2000CI or SX-2000CO
Connector/Cable	1 interface, RJ45 Connector, Shielded Category 5 twisted pair cable (CAT5-STP)
Maximum Cable Distance	800m
Speaker Line Failure Detection Section	
Connector/Cable	Removable terminal block, SP/AMP: 8 pins, STANDBY AMP: 2 pins, AWG 24 – AWG 16
Maximum Input	100Vrms, 5Arms
Fault Detection System	Short circuit, open circuit, ground fault
Method	Impedance or End of line
End of Line	In case of normal: Terminated by 470kΩ between the speaker line and the shield In case of open: Opened between the speaker line and the shield
Impedance	Minimum load: 2kΩ (5W) at 100V line
Control Input	8 inputs, no-voltage make contact input, open voltage: 40V DC or less, short-circuit current: 2mA, photo coupler input, removable terminal block (6 pins)
Control Output	8 outputs, C contact, no-voltage make contact output, relay contact output (withstand voltage: 40V DC, control current: 2 – 300mA), removable terminal block (6 pins)
Operating Temperature	0°C to +40°C
Operating Humidity	35% to 80% RH (no condensation)
Finish	Panel: Aluminum, black, alumite, Case: Surface-treated steel plate
Dimensions	482 (W) x 88.4 (H) x 349 (D)mm
Weight	7.1kg
Accessory	Removable terminal plug (8 pins) x 4, Removable terminal plug (6 pins) x 8, Removable terminal plug (4 pins) x 1, Removable terminal plug (2 pins) x 1, Rack mounting screw x 4

SX-2100AO

Audio Output Unit



The SX-2100AO is an audio output of the matrix system and can be mounted in an EIA equipment rack (2U size). Multiple units can be decentralized in a whole system. It is equipped with eight audio outputs and two inputs can be mixed and output. It is also equipped with eight control inputs, and eight control outputs. The SX-2100AO receives audio signals from the audio input unit via digital transmission, but an analog audio input function (1 channel) enables simultaneous all-zone calls for use in emergency situations. Audio output levels meters provided for each output channel. Volumes can be adjusted for each channel using the volume control can be locked. Any output channel can be monitored using the internal speaker. Two channels of local audio inputs with control inputs are provided as the dedicated audio inputs. Its functions include on amplifier switching function that automatically switches the power amplifier to the standby amplifier if the power amplifier fails, and a surveillance function that self-diagnoses the speaker lines. Equipped with two channels of interfaces for connecting to the Emergency Power Supply units, making it possible to configure the system to operate during a power failure. The SX-2100AO has two power inputs and can support a dual-redundant power supply system.

SX-2000AO

Audio Output Unit

EN 54
16



The SX-2000AO is an audio output of the matrix system and can be mounted in an EIA equipment rack (2U size). Multiple units can be decentralized in a whole system. It is equipped with eight audio outputs, and two inputs can be mixed and output. It is also equipped with eight control inputs, and eight control outputs. The SX-2000AO receives audio signals from the audio input unit via digital transmission, but an analog audio input function (1 channel) enables simultaneous all-zone calls for use in emergency situations. Audio output levels are indicated on the level meters provided for each output channel. Volumes can be adjusted for each channel using the volume controls on the front panel or the SX-2000 software. The volume controls can be locked. Any output channel can be monitored using the internal speaker. One control IN/OUT interface allows the number of control inputs and outputs to be increased. It is equipped with an emergency audio input and a 24V emergency cutoff input. The SX-2000AO has two power inputs and can support a dual-redundant power supply system.

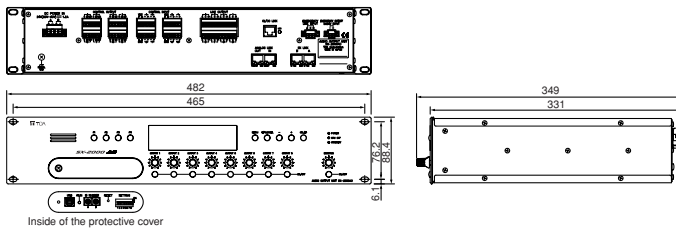

SPECIFICATIONS

*0dB = 1V

Power Source	Usable power supply unit: VX-200PS 24V DC (operational range: 20V – 40V DC) Two power inputs construction enables dual-redundant power supply.
Current Consumption	1.2A or less (maximum value in the power operating range) 0.79A or less (when operated on 24V DC) Note: But except current consumption of the external equipment of which power is supplied from the unit.
Indication	18 alphanumeric characters, Level indication (8 outputs, monitor), Status indicators, Power indicator, Standby indicator, CPU OFF indicator
Operation	Function button, Output level control, Monitor speaker volume control, ON/OFF switch, Operation button
Audio Output	8 outputs, 0dB*, suitable load: 600Ω or above, electronically-balanced output changeable into transformer-balanced output (optional), removable terminal block (12 pins), monitoring possible using built-in speaker
Audio Output Characteristic	Frequency response: 20 – 20,000Hz Sampling frequency: 48kHz D/A converter: 24 bit
Emergency Line Input	Emergency signals switched and sent to Input 1 (H, C, E) by relay removable terminal block (3 pins), Emergency audio message is output from all audio equipment connected input is connected when the power or an emergency-cutoff 24V signal is cut off.
Emergency-Cutoff 24V Input	1 input, input current: 5mA or less, removable terminal block (2 pins), cancellation possible using DIP switch
SX Link Network I/F Connection Cable/Device	2 × 100 BASE-TX circuits, RJ45 connector, decentralized installation possible Shielded Category 5 twisted pair cable (CAT5-STP) To be connected via the switching hub specified by TOA Note: This network must be made completely independent from other LAN. 100m (between this unit and a switching hub)
Analog Link Input/Output Connector Connection Cable Maximum Cable Distance	Input: 1 input, RJ45 connector Output: 1 output, RJ45 connector Shielded Category 5 twisted pair cable (CAT5-STP) (1 pair of audio wire + 1 pair of CPU OFF + 1 pair of control wire (system reset/standby) + 1 pair of connection check wire) Total length of analog audio link: 800m
C/CO Link Usable Unit Connector/Cable Maximum Cable Distance	SX-2000CI or SX-2000CO 1 interface, RJ45 Connector, Shielded Category 5 twisted pair cable (CAT5-STP) 800m

Control Input	8 inputs, no-voltage make contact input, open voltage: 40V DC or less, short-circuit current: 2mA, photo coupler input, removable terminal block (6 pins)
Control Output	8 outputs, C contact, no-voltage make contact output, relay contact output (withstand voltage: 40V DC, control current: 2 – 300mA), removable terminal block (6 pins)
Operating Temperature	0°C to +40°C
Operating Humidity	35% to 80% RH (no condensation)
Finish	Panel: Aluminum, black, alumite, Case: Surface-treated steel plate
Dimensions	482 (W) × 88.4 (H) × 349 (D)mm
Weight	6.2kg
Accessory	Removable terminal plug (12 pins) × 2, Removable terminal plug (6 pins) × 8, Removable terminal plug (4 pins) × 1, Removable terminal plug (3 pins) × 1, Removable terminal plug (2 pins) × 1, Rack mounting screw × 4
Option	Line transformer: IT-450

SX-2000CI

Control Input Unit

EN 54
16



The SX-2000CI is a control input of the matrix system and can be mounted in an EIA equipment rack (1 U size). Multiple units can be decentralized in a whole system. It is equipped with 32 control input channels. Control input line failure can be detected by connecting resistors to its line. The indicators on the front panel monitor the control input line status. The SX-2000CI has two power inputs and can support a dual-redundant power supply system.

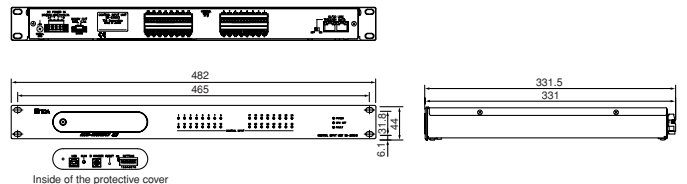

SPECIFICATIONS

*0dB = 1V

Power Source	Usable power supply unit: VX-200PS 24V DC (operational range: 20V – 40V DC) Two power inputs construction enables dual-redundant power supply.
Current Consumption	0.7A or less (maximum value in the power operating range) 0.55A or less (when operated on 24V DC)
Indication	Control input indicator (32), Power indicator, CPU OFF indicator, FAULT indicator
Control Input	32 inputs, no-voltage make contact input, open voltage: 24V DC, short-circuit current: 2mA, photo coupler input, removable terminal block (16 pins)
Surveillance Section for The Control Input Lines	Connection resistance to make the function inactive: 20kΩ ±5% Connection resistance to make the function active: 10kΩ ±5% Connector cable: Twisted pair cable (shielded type is recommended) Maximum cable distance: 10m
C/CO Link Input/Output Connector Connection Cable Maximum Cable Distance	Input: 1 input, Output: 1 output RJ45 Connector Shielded Category 5 twisted pair cable (CAT5-STP) (1 pair of data wire + 1 pair of control wire) 800m
24V DC Output Output Voltage Maximum Feeding Current Connector	24V DC ±10% or less Output: 1 output, RJ45 connector 100mA Removable terminal block (2 pins)
Operating Temperature	0°C to +40°C
Operating Humidity	35% to 80% RH (no condensation)
Finish	Panel: Aluminum, black, alumite, Case: Surface-treated steel plate
Dimensions	482 (W) × 44 (H) × 331.5 (D)mm
Weight	3.6kg
Accessory	Removable terminal plug (16 pins) × 4, Removable terminal plug (4 pins) × 1, Removable terminal plug (2 pins) × 1, Rack mounting screw × 4

SX-2000CO

Control Output Unit

EN 54
1.6



The SX-2000CO is a control output of the matrix system and can be mounted in an EIA equipment rack (1 U size). Multiple units can be decentralized in a whole system. It is equipped with 32 control output channels. The indicators on the front panel monitor the control output line status. Control output status when the CPU turns off can be set. The SX-2000CO has two power inputs and can support a dual-redundant power supply system.

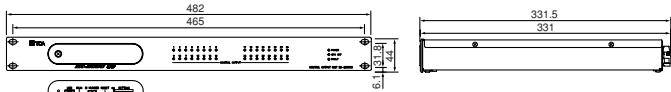

Inside of the protective cover

SPECIFICATIONS

*0dB = 1V

Power Source	Usable power supply unit: VX-200PS 24V DC (operational range: 20V - 40V DC) Two power inputs construction enables dual-redundant power supply.
Current Consumption	0.34A or less (maximum value in the power operating range) 0.29A or less (when operated on 24V DC)
Indication	Control output indicator (32), Power indicator, CPU OFF indicator, FAULT indicator
Control Output	32 outputs, no-voltage make contact output, relay contact output, (withstand voltage: 40V DC, control current: 2mA to 300mA), removable terminal block (16 pins)
CI/CO Link	Input/Output Connector Input: 1 input, Output 1 output RJ45 Connector Connection Cable Shielded Category 5 twisted pair cable (CAT5-STP) (1 pair of data wire + 1 pair of control wire) Maximum Cable Distance 800m
Operating Temperature	0°C to +40°C
Operating Humidity	35% to 80% RH (no condensation)
Finish	Panel: Aluminum, black, alumite, Case: Surface-treated steel plate
Dimensions	482 (W) x 44 (H) x 331.5 (D)mm
Weight	3.6kg
Accessory	Removable terminal plug (6 pins) x 16, Removable terminal plug (4 pins) x 1, Rack mounting screw x 4

RM-200SF

Remote Microphone

EN 54
1.6



The RM-200SF is a Fireman's Microphone of the matrix system. It is equipped with an Emergency key, permitting it to be used as a remote microphone for emergency broadcast. Zone selection and microphone announcement can be made at the time of emergency broadcast. It offers a surveillance function to detect failures including microphone element failure. The RM-200SF has three function keys that can be Connecting the optional RM-210 Extension units to the RM-200SF expands the number of function keys and indicators in blocks of ten.

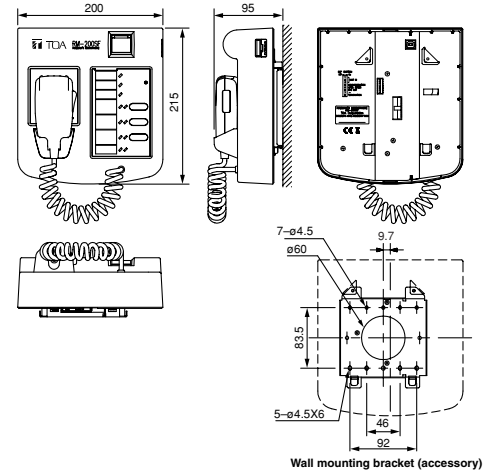

Wall mounting bracket (accessory)

SPECIFICATIONS

* 0 dB = 1V

Power Source	24V DC (operating range: 15 - 40V DC, supplied from the SX-2100A1 or SX-2100A1 audio input unit)
Current Consumption	240mA or less
Audio Output	0dB*, transformer-balanced
Distortion	1% or less
Frequency Response	200 - 15,000Hz
S/N Ratio	60dB or more
Microphone	Unidirectional electret condenser microphone with AGC (ON/OFF selectable), microphone element failure detectable by using a built-in small oscillator
Volume Control	Microphone volume control, Monitor speaker volume control, Chime volume control (using the software)
Connection Cable	Shielded CPEV cable (each one pair of audio wire, data wire, monitor/control wire, and power supply wire) or Shielded Category 5 twisted pair cable (CAT5-STP), M3 screw terminal
Maximum Cable Distance	800m
No. of Connectable Expansion	Max. 5 units
Monitor Speaker	Built inside
Operation	Emergency keys, Function keys, CPU switch, Reset switch
Indicator	Status indicators, Power indicator, Failure indicator, CPU indicator, Selection indicators, Microphone indicator, Broadcast status indicator
Operating Temperature	0°C to +40°C
Operating Humidity	35% to 80% RH (no condensation)
Finish	ABS resin, blueish gray (PANTONE 538 or its equivalent)
Dimensions	200 (W) x 215 (H) x 95 (D)mm
Weight	1.48kg (with wall mounting bracket unit)
Accessory	EMC clamp x 1, Wall mounting bracket unit x 1, Wall mounting screw x 2, Box mounting screw x 2
Option	Remote microphone extension: RM-210
Applicable Box	YS-11A

Conductor diameter of the main line cable vs. Maximum cable length

No. of extension unit Conductor diameter	Conductor diameter					
	RM-200SF only	RM-200SF + RM-210 x 1	RM-200SF + RM-210 x 2	RM-200SF + RM-210 x 3	RM-200SF + RM-210 x 4	RM-200SF + RM-210 x 5
ø0.65mm	230	190	170	150	130	110
ø0.9mm	460	380	330	290	260	230
ø1.2mm	800	670	570	500	450	400
CAT5-STP	140	120	100	90	80	70

(unit: m)

RM-200SA

Remote Microphone

EN 54
16



The RM-200SA is a remote microphone designed for the Matrix System. It is equipped with 13 function switches that can be used to select individual zones or zone groups a covered switch and corresponding indicators. The optional RM-210 Remote Microphone Extension permits switches and indications to be expanded in 10-piece units.

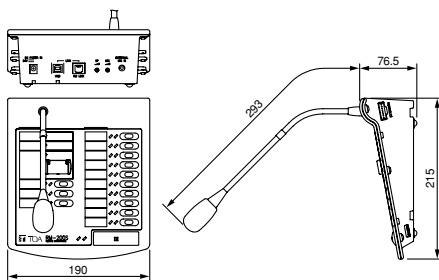

SPECIFICATIONS

* 0 dB = 1 V

Power Source	24V DC (operating range: 15 – 40V DC, supplied from the SX-2000Ai or SX-2100Ai audio input unit) or DC input power supply connector (when the optional AD-246 power supply unit used) Usable DC power supply plug: 5.5mm outer diameter, 2.1mm inner diameter 9.5mm long, and non-polarity type.
Current Consumption	290mA or less
Audio Output	0dB*, 600Ω, balanced
External Microphone Input	-40dB*, 2.2kΩ, unbalanced, mini jack for electret condenser microphone (phantom power supply: 3V DC)
Distortion	1% or less
Frequency Response	100 – 20,000Hz
S/N Ratio	60dB or more
Microphone	Unidirectional electret condenser microphone with AGC (ON/OFF selectable)
Chime	Built inside (PCM sound source), monitoring possible using built-in speaker
Level Control	Microphone sensitivity control, monitor speaker volume control, chime (adjustable using the software)
Connection Cable	Main line: Shielded CPEV cable(1 pair of audio wire + 1 pair of data wire + 1 pair of monitor/control wire + 1 pair of supply wire) or Shielded Category 5 twisted pair cable (CAT5-STP) Branch line: Shielded Category 5 twisted pair cable for (CAT5-STP), RJ45 connector
Maximum Cable Distance	800m
Number of Connectable Expansion	Max. 4 units
Monitor Speaker	Built inside
Operation	Function switch, Covered switch, Broadcast switch
Indicator	Power indicator, Failure indicator, Function switch indicator, Covered switch indicator, Broadcast switch indicator
Operating Temperature	0°C to +40°C
Operating Humidity	35% to 80% RH (no condensation)
Finish	ABS resin, blueish gray
Dimensions	190 (W) × 76.5 (H) × 215 (D)mm (excluding microphone)
Weight	880g
Option	Remote microphone extension: RM-210, Wall mounting bracket: WB-RM200, Electret condenser microphone: WH-4000A, YP-M101, YP-M301 etc.

Conductor diameter of the main line cable vs. Maximum cable length
(when DC power is supplied only from the SX-2100Ai)

No. of extension unit Conductor diameter	RM-200SA only	RM-210 × 1	RM-210 × 2	RM-210 × 3	RM-210 × 4
ø0.65mm	230	190	170	150	130
ø0.9mm	460	380	330	290	260
ø1.2mm	800	670	570	500	450
CAT5-STP	140	120	100	90	80

(unit: m)

RM-210

Remote Microphone Extension

EN 54
16

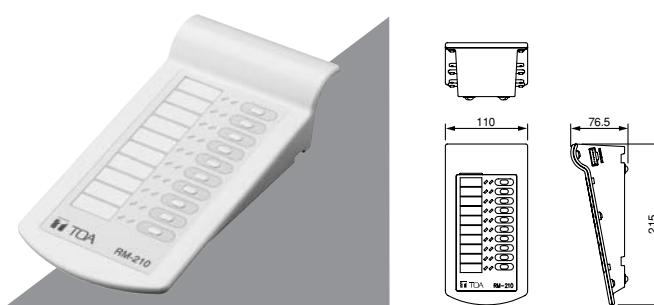

The RM-210 is an extension unit for increasing the number of function keys of RM-200SA, Remote Microphones.

SPECIFICATIONS

Current Consumption	20mA max. (in terms of RM-200M's DC power input) 75mA max. (in terms of DC power inputs of RM-200X and RM-200XF) 80mA max. (in terms of DC power inputs of RM-200SA and RM-200SF)
Connection	Connection by way of dedicated cable
Number of Function Keys	10
Finish	ABS resin, blueish gray (PANTONE 538 or its equivalent)
Dimensions	110 (W) × 76.5 (H) × 215 (D)mm
Weight	350g
Accessory	Extension cable × 1, Linkage bracket A × 2, Linkage bracket B × 1, Screw for linkage bracket × 12
Applicable Unit (option)	RM-200M, RM-200SA, RM-200SF, RM-200X, RM-200XF

RM-200RJ

Terminal Unit

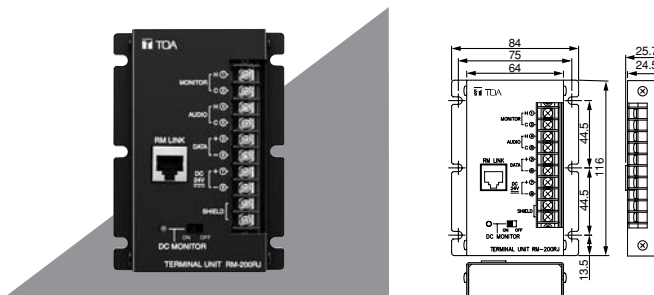

The RM-200RJ is designed to convert the RJ45 connector into a screw terminal block. It is used to connect between a trunk cable (such as CPEV cable) and a feeder cable (such as LAN cable) in wiring a remote microphone. The built-in indicator shows the voltage status of DC power cable when the remote microphone cable for the SX-2000 series system is connected.

SPECIFICATIONS

Applied Voltage	40V or less
Withstand Voltage	1A
Voltage Indicator	Monitor terminals: Terminal No. 7 (+) and terminal No.8 (-), extinguish voltage: 14V or less, lighting voltage: 21V or more, indicator ON/OFF switchable
Connector	RJ45 Connector: 1
Terminal	M3 screw terminal (10 pins), distance between barriers: 6.62mm
Operating Temperature	0°C to +40°C
Operating Humidity	35% to 80% RH (no condensation)
Finish	Surface-treated steel plate, black, paint
Dimensions	84 (W) × 116 (H) × 25.7 (D)mm
Weight	250g

SX-200RM Remote Microphone Interface Module

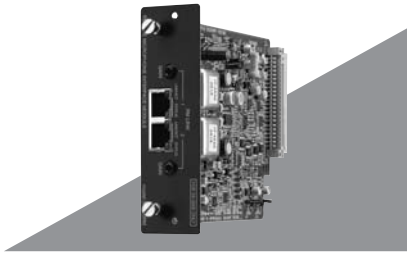

The SX-200RM is a dedicated remote microphone module for the SX-2000 Series audio input unit and can be used to connect two remote microphones. Input sensitivity can be adjusted.

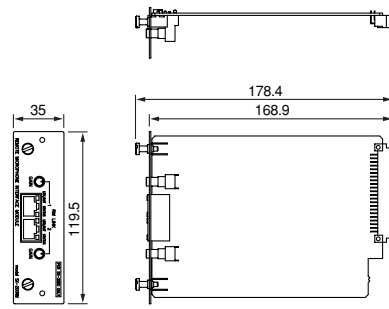

SPECIFICATIONS

* 0dB = 1V

Audio Input	2 inputs, 0dB*, RJ45 Connector
Audio Input Characteristic	Sampling Frequency: 48kHz A/D converter: 24 bit
Power Feed	Max. 1A per Connector
Level Control	Audio input (0 to +12dB)
Finish	Panel: Pre-coated steel plate, black, 30% gloss
Dimensions	35 (W) x 119.5 (H) x 178.4 (D) mm
Weight	190g

D-936R Stereo Select Input Module

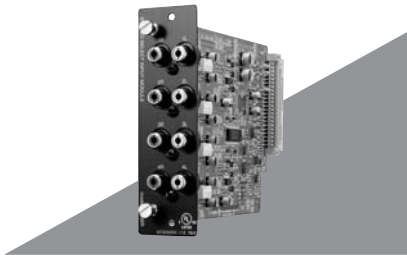

The D-936R is a dedicated 4 stereo input module designed for use with the SX-2100AI and equipped with standard RCA pin jacks.

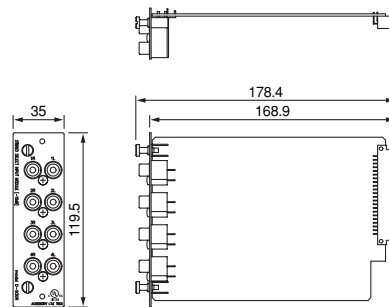

SPECIFICATIONS

* 0dB = 0.775V

Input	monaural x 2 -10dB*, 10Ω, RCA pin jack
A/D Converter	24 bits
Frequency Response	20 - 20,000Hz, ±1dB (+4dB* input)
Sampling Frequency	48 kHz
Dynamic range	100dB (IHF-A weighted) or more
Total Harmonic Distortion	0.05% or less
Finish	Panel: Pre-coated steel plate, black, 30% gloss
Dimensions	35 (W) x 119.5 (H) x 178.4 (D) mm
Weight	145g

D-921F Mic/Line Input Module (24 bits Monaural Type)



The D-921F is a dedicated 2-channel microphone/line input module designed for use with the SX-2100AI and equipped with XLR connectors.

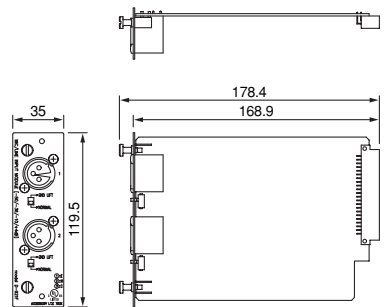

SPECIFICATIONS

* 0dB = 0.775V

Input	2 channels, Mic/Line changeable Mic: -50/-36dB*, 4.7kΩ, electronically-balanced, equivalent to XLR-3-31 type Line: -10/+4dB*, 10kΩ, electronically-balanced, equivalent to XLR-3-31 type Phantom power supply: 12V (can be used when set for the microphone) Ground lift switch
A/D Converter	24 bits
Frequency Response	20 - 20,000Hz, ±1dB (+4dB* input)
Sampling Frequency	48 kHz
Dynamic range	100dB (IHF-A weighted) or more (+4dB* input)
Total Harmonic Distortion	0.05% or less (+4dB* input)
Finish	Panel: Pre-coated steel plate, black, 30% gloss
Dimensions	35 (W) x 119.5 (H) x 178.4 (D) mm
Weight	150g

D-921E Mic/Line Input Module (24 bits Monaural Type)

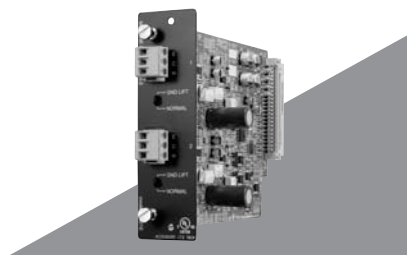

The D-921E is a dedicated 2-channel microphone/line input module designed for use with the SX-2100AI and equipped with removable terminal block type connectors.

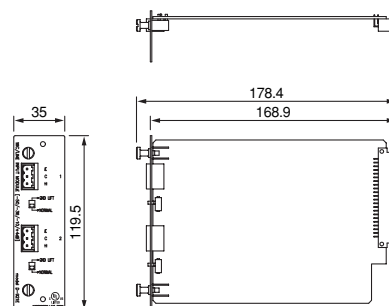

SPECIFICATIONS

* 0dB = 0.775V

Input	2 channels, Mic/Line changeable Mic: -50/-36dB*, 4.7kΩ, electronically-balanced, removable terminal block (3 pins) Line: -10/+4dB*, 10kΩ, electronically-balanced, removable terminal block (3 pins) Phantom power supply: 12V (can be used when set for the microphone) Ground lift switch
A/D Converter	24 bits
Frequency Response	20 - 20,000Hz, ±1dB (+4dB* input)
Sampling Frequency	48 kHz
Dynamic range	100dB (IHF-A weighted) or more (+4dB* input)
Total Harmonic Distortion	0.05% or less (+4dB* input)
Finish	Panel: Pre-coated steel plate, black, 30% gloss
Dimensions	35 (W) x 119.5 (H) x 178.4 (D) mm
Weight	140g
Accessory	Removable terminal plug (3 pins, preinstalled on the unit) x 2

D-922F Mic/Line Input Module (20 bits Monaural Type)



The D-922F is a dedicated 2-channel microphone/line input module designed for use with the SX-2100AI and equipped with XLR connectors.

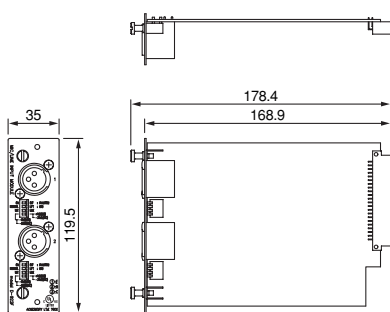

SPECIFICATIONS

* 0dB = 0.775V

Input	2 channels, -50/-36/-10/+4dB* (Selectable with the DIP switch), 4.7kΩ, electronically-balanced, equivalent to XLR-3-31 type Phantom power supply 12V (can be set with the DIP switch) Ground lift switch (can be set with the DIP switch)
A/D Converter	20 bits
Frequency Response	20 – 20,000Hz, ±1dB (+4dB* input)
Sampling Frequency	48 kHz
Dynamic range	85dB (IHF-A weighted) or more (+4dB* input)
Total Harmonic Distortion	0.2% or less (+4dB* input)
Finish	Panel: Pre-coated steel plate, black, 30% gloss
Dimensions	35 (W) x 119.5 (H) x 178.4 (D) mm
Weight	135g

D-922E Mic/Line Input Module (20 bits Monaural Type)

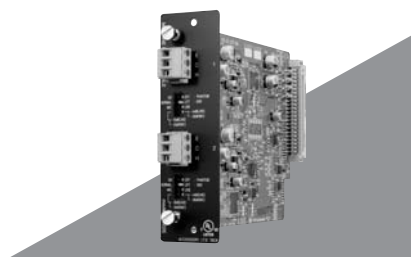

The D-922E is a dedicated 2-channel microphone/line input module designed for use with the SX-2100AI and equipped with removable terminal block type connectors.

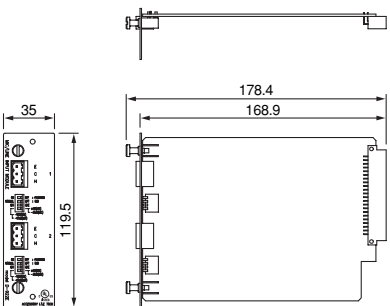

SPECIFICATIONS

* 0dB = 0.775V

Input	2 channels, -50/-36/-10/+4dB* (Selectable with the DIP switch), 4.7kΩ, electronically-balanced, removable terminal block (3 pins) Phantom power supply 12V (can be set with the DIP switch) Ground lift switch (can be set with the DIP switch)
A/D Converter	20 bits
Frequency Response	20 – 20,000Hz, ±1dB (+4dB* input)
Sampling Frequency	48 kHz
Dynamic range	85dB (IHF-A weighted) or more (+4dB* input)
Total Harmonic Distortion	0.2% or less (+4dB* input)
Finish	Panel: Pre-coated steel plate, black, 30% gloss
Dimensions	35 (W) x 119.5 (H) x 178.4 (D) mm
Weight	125g
Accessory	Removable terminal plug (3 pins, preinstalled on the unit) x 2

VP-2064/2112/2241/2421 Power Amplifiers



- VP-2064 (60 W-by-4 channels)
- VP-2122 (120 W-by-2 channels)
- VP-2241 (240 W-by-1 channel)
- VP-2421 (420 W-by-1 channel)

Power Amplifier uses the VP-200VX Power Amplifier Input Module per channel.

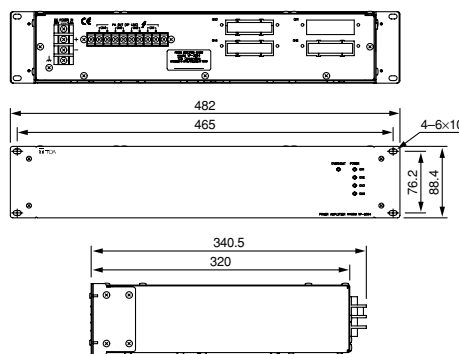

SPECIFICATIONS

Model No.	VP-2064 Power Amplifier 4 × 60W	VP-2122 Power Amplifier 2 × 120W	VP-2241 Power Amplifier 1 × 240W	VP-2421 Power Amplifier 1 × 420W
Power Source	28V DC (operating range: 20 – 40V DC) M4 screw terminal, distance between barriers: 12mm			
Current Consumption (EN60065)	4.8A in total		4.8A	7.6A
Rated Output Power	60W x 4	120W x 2	240W	420W
Output Voltage/Impedance	100V/167Ω, 70V/83Ω, 50V/41Ω (selectable by the internal wiring change)	100V/83Ω, 70V/41Ω, 50V/21Ω (selectable by the internal wiring change)	100V/41Ω, 70V/21Ω, 50V/10Ω (selectable by the internal wiring change)	100V/24Ω, 70V/12Ω, 50V/6Ω (selectable by the internal wiring change)
Number of Channels	4	2	1	
Input	Specified by input module VP-200VX			
Number of Module Slots	4, usable module: VP-200VX	2, usable module: VP-200VX	1, usable module: VP-200VX	
Output	Power amplifier output (speaker line): M3.5 screw terminal, distance between barriers: 8.8mm			
Frequency Response	40 – 16,000Hz, ±3dB (at 1/3 rated output)			
Distortion	Under 1% (at rated output, 1kHz)			
S/N Ratio	Over 80dB			
Panel Indicator	Channel power indicator: 4 channels, dual colour LED Overheat indicator: Yellow LED	Channel power indicator: 2 channels, dual colour LED Overheat indicator: Yellow LED	Channel power indicator: 1 channels, dual colour LED Overheat indicator: Yellow LED	
Operating temperature	0° to +40°C			
Finish	Panel: Surface-treated steel plate, black, 30% gloss, paint			
Dimensions	482 (W) x 88.4 (H) x 340.5 (D)mm			
Weight	11.2kg	9.1kg	8.1kg	9.5kg
Accessory	Rack mounting screw x 4, Fiber washer x 4			

VX-2000DS Emergency Power Supply

EN 54
4



The VX-2000DS Emergency Power Supply Unit supplies the DC power to each equipment in the SX-2000 system by connecting the VX-200PS Power Supply Unit.

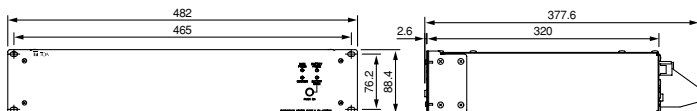
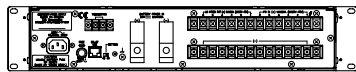

SPECIFICATIONS

Power Source	230V AC, 50/60Hz
Power Consumption	240W max.
Applicable Battery	Panasonic NP series (12V x 2 or 4)
Charging Method	Trickle charging
Charging Current	5A max
Charging Output Voltage	27.3V \pm 0.3V (at 25°C) Temperature correction coefficient: $-40\text{mV}/^\circ\text{C}$
Power Supply Input	6 M4 screw terminal, distance between barriers: 11mm
DC Power Output	6 (25A max. each) M4 screw terminal, distance between barriers: 11mm
Control Connector	RJ45 female connector for connecting the VX-2000SF Surveillance Frame. Twisted-pair straight cable (TIA/EIA-568A standard) Type of control signal: Battery check, AC power status, DC power status, charging circuit failure, and battery failure
Battery Connection	1 pair of positive and negative terminals Applicable cable diameter: AWG 6 – AWG 1/0
Operating Temperature	0° to +40°C
Finish	Panel: Surface-treated steel plate, black, 30% gloss, paint
Dimensions	482 (W) x 88.4 (H) x 377.6 (D)mm
Weight	10.5kg
Accessory	Rack mounting screw x 4, Fiber washer x 4, Blade fuse (40A) x 3, Fuse (T3.15A L) x 1, Power cable x 1

VX-2000PF Power Supply Frame

EN 54
4



The VX-2000PF permits the VX-200PS Power Supply Unit to be mounted in an equipment rack. Up to 3 VX-200PS units can be installed in the unit.

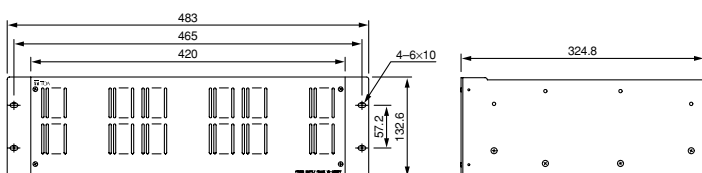
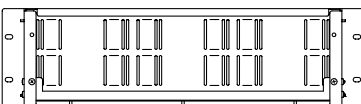

SPECIFICATIONS

Finish	Panel: Surface-treated steel plate, black, 30% gloss, paint
Dimensions	483 (W) x 132.6 (H) x 324.8 (D)mm
Weight	5.5kg
Product Composition	Side panel x 2, Chassis x 1, Front panel x 1
Accessory	Rack mounting screw x 4, Fiber washer x 4
Usable Unit	VX-200PS (up to 3)

VX-200PS Power Supply Unit

EN 54
4

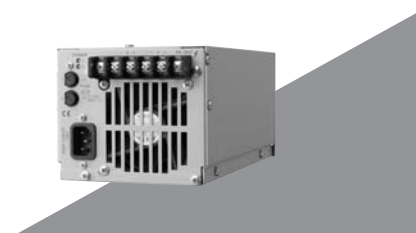

The VX-200PS Power Supply Unit is mounted in the VX-2000PF Power Supply Frame when in use.

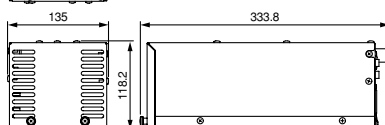
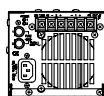

SPECIFICATIONS

Power Source	230V AC, 50/60Hz
Power Consumption	580W
PS OUT	Rated output: 210W (29V, 7.25A) x 2 Peak output: 400W x 2 M4 screw terminal, distance between barriers: 11mm
Operating Temperature	0° to +40°C
Applicable Frame	VX-2000PF
Finish	Surface-treated steel plate
Dimensions	135 (W) x 118.2 (H) x 333.8 (D)mm
Weight	13.2kg
Accessory	Fuse (T3.15A L) x 1, Power cable x 1

SYSTEM DIAGRAM

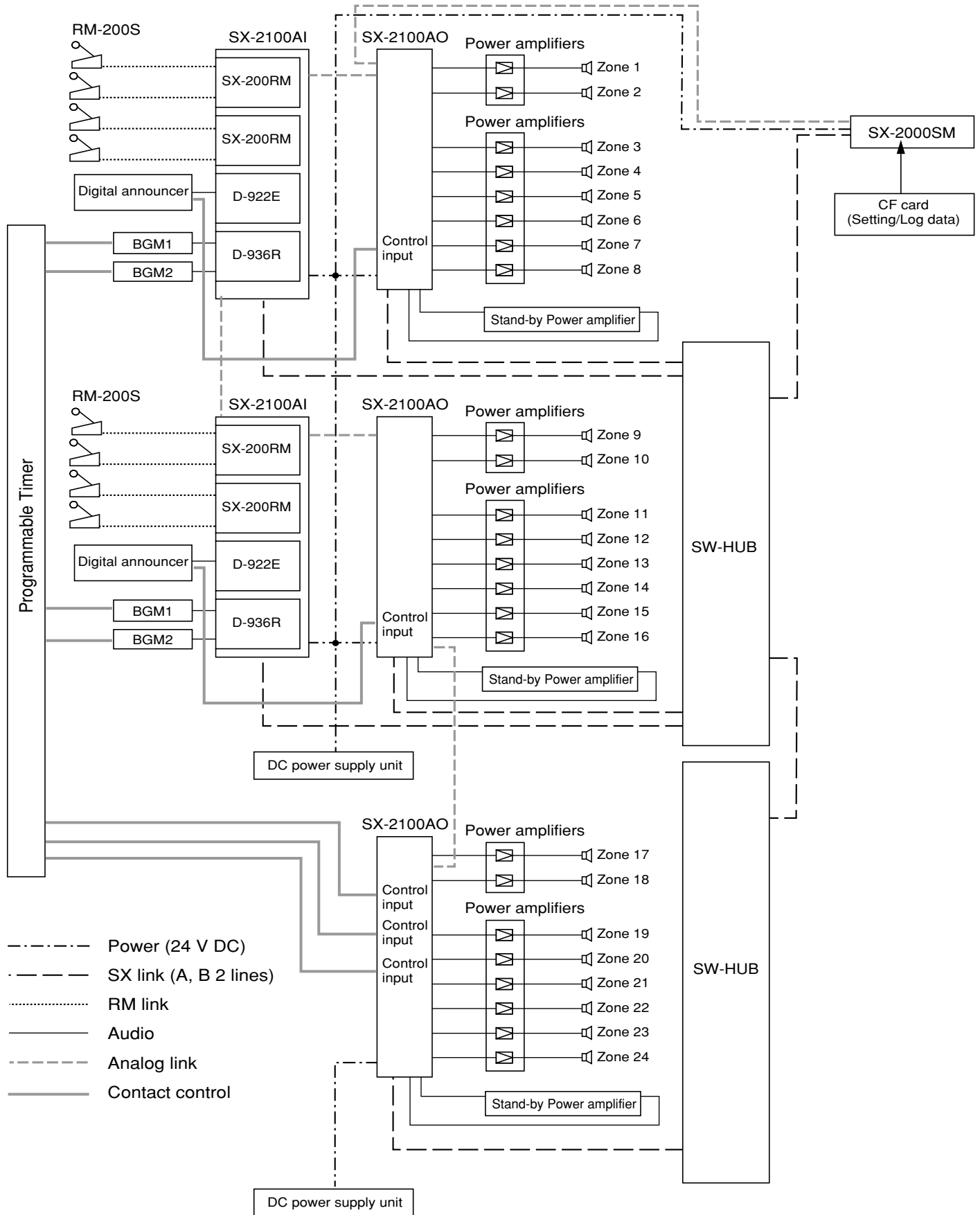

[Components]

RM-200S: Remote microphone
 SX-2100AI: Audio input unit
 SX-200RM: Remote microphone interface module
 D-922E: Microphone/Line input module

D-936R: Stereo input module
 SX-2100AO: Audio output unit
 SX-2000SM: System manager

Software

■ SX-2000 SETTING SOFTWARE OUTLINE

The SX-2000 Setting Software allows the settings data needed for operation of SX-2000 Series Smart Matrix Systems to be created using the browser software on a personal computer.

These settings are saved in the form of a file with the extension ".s2d."

This file can be saved to a Compact Flash (CF) card.

■ SETTING

NETWORK:

IP address, subnet mask, default gateway, and HTTP server port

CONFIGURATION:

The name of the SX-2000SM, SX-2100AI, SX-2000AO/SX-2100AO, the zones, the number of SX-2100AI units, the modules, the RM-200SA Remote Microphone Extension units, the PAD (input sensitivity), the phantom power supply, the output channels zone(s), can be set.

INPUT/OUTPUT

The name of the input channel, the remote microphone, the control output for the SX-2000SM and SX-2000AO/SX-2100AO, the type of sound source, the Fade-in/Fade-out function, the number of RM-210 units, the volume of the chime broadcast by the Remote Microphone, can be set.

SYSTEM

Input sound source priority levels, and the initial sound volume levels for the audio input and output sources can be set.

■ PATTERN

There are five types of patterns: BGM patterns, General-Purpose Broadcast patterns, Volume patterns, Control Output patterns and RM Zone Selection patterns.

BGM patterns

A maximum of 16 patterns and BGM pattern name, the BGM pattern number, input name, the slot sound source being used, can be set.

General-Purpose Broadcasting patterns

A maximum of 128 patterns, the General-purpose broadcast pattern name, the input name, the slot sound source being used, can be set.

Volume patterns

A maximum of 128 patterns, the Volume pattern name and number, the change range of volume level, the zones in which the volume is changed, can be set.

Control Output patterns

A maximum of 256 patterns, the Control output pattern name and number, the contact output terminals to perform control, can be set.

RM Zone Selection patterns

A maximum of 128 patterns, the RM zone selection pattern name and number, and the zones in which Remote Microphone broadcasts are made, can be set.

(Note) Patterns

A "pattern" refers to a single "unit" comprised of various audio input sources (input channels), broadcast zone settings, and so on. By allocating patterns to the function keys on the SX-2100AI (Audio Input Unit), SX-2000AO/SX-2100AO (Audio Output Unit), RM-200SA (Remote Microphone) and/or RM-210 (Remote Microphone Extension), broadcasts can be made simultaneously from multiple sound sources to multiple zones. Set patterns can also be allocated to the control inputs on the SX-2000SM and SX-2000AO/SX-2100AO to allow broadcasts to be made as specified by the pattern whenever the control input receives an activating signal.



■ CONTROL INPUT

Function allocations for the SX-2000SM and SX-2000AO/SX-2100AO control inputs, and for the SX-2100AI and SX-2000AO/SX-2100AO function keys can be set.

Functions (None/ General broadcast/ BGM pattern change or end/ Volume change/ Time adjustment) for the SX-2000SM can be selected.

The functions to be assigned to the function keys on the front panel of the SX-2100AI, and the names of the function keys on the SX-2100AI's front panel, can be set.

The functions (None/ BGM pattern change or end) to be assigned to the function keys on the SX-2100AI's front panel are selected.

The functions can be assigned to the function keys on the front panel and the control inputs of the SX-2000AO/SX-2100AO.

The names of the function keys on the front panel and the control inputs of the SX-2000AO/SX-2100AO can be set.

The functions (None/ BGM pattern change or end) to be assigned to the function keys on the SX-2000AO/SX-2100AO's front panel are selected.

■ RM FUNCTION KEY

Functions to the function keys on the Remote Microphone are assigned.

The name assigned to the Remote Microphone, the Remote Microphone's "Talk key" operation method, an appropriate time-out period after which Remote Microphone announcements are automatically terminated if the user fails to turn off the microphone power, the type of chime tone to be sounded before and after Remote Microphone announcements are made, the function key names, the functions to be assigned to the function keys, can be set.

■ UTILITY

The SX-2000SM System Manager is capable of saving the system's operation histories to a CF card in the form of a log file with the extension ".s2l," and such saved operation logs can be displayed using setting software.

A maximum of 10,000 histories can be displayed. It is also possible to export the displayed data in the form of an Excel CSVs file.

The data set using the Setting Software as a file named SX-2000.s2d, which is usable by the SX-2000 system, can be output.

The settings file can be saved to a CF card, and allowing the SX-2000SM to read this card in order to begin operation of the system.

Settings data can be output in CSV file format.



TOA Corporation

<http://www.toa.jp/>

Specifications are subject to change without notice.
Printed in Japan (1105) 833-61-715-2B u